



Attachment of Cold Formed Steel to Concrete Structures

Code requirements for bracing, resistance to transfer loads and seismic considerations of non-load bearing partitions are based on ASCE and ASTM standards. Many of the allowable options for bracing of these non-load bearing partitions are covered in TSIB Technical Bulletin 20.100.

Attachment of floor and ceiling tracks (top and sill) to concrete and/or metal pan decking shall comply with ASTM C 754. Attachment of track to non-load bearing partitions to concrete substrates may be attached using power driven/actuated fasteners (see detail).

ASCE 7-05 prohibits the use of power actuated fasteners in tension load applications for Seismic Design Categories D, E and F, unless approved for such loading. Authorities do not consider attaching tracks (top and sill) of non-load bearing partitions as a tension load.

LIMITATIONS:

The attachment procedures listed herein are limited to non-load bearing partitions weighing less than 15 pounds per square foot, 14 feet in height and not subject to wind loads. All fasteners shall be corrosion resistant and driven "home." This document is not intended to address attachment of suspended bulk heads, soffits or curtain walls.

Spacing of Power Driven Fasteners

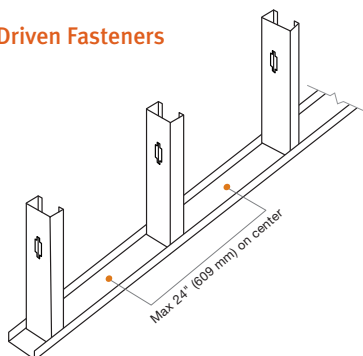

SPACING:

- Attachment shall not exceed 24 inches on center
- Attachment shall start no farther than two (2) inches from the ends of the tracks

Power-actuated Fasteners

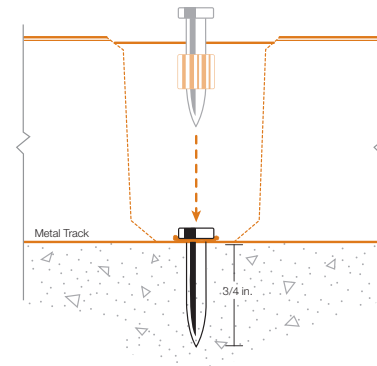

FASTENERS:

- A power actuated/driven fastener with a minimum .145 inch diameter pin
- Minimum 3/4 inch pin in length
- 3/4 inch penetration and driven home
- Provide a minimum 50 pound pull out value

All OSHA regulations shall be followed including but not limited to eye and ear protection. This document is for general information purposes only and not intended for a specific project/detail. The TSIB provides no warranty express or implied.

This technical document is to serve as a guideline and is not intended for any specific construction project. TSIB makes no warranty or guarantee, expressed or implied.